

## Accessories Catalogue

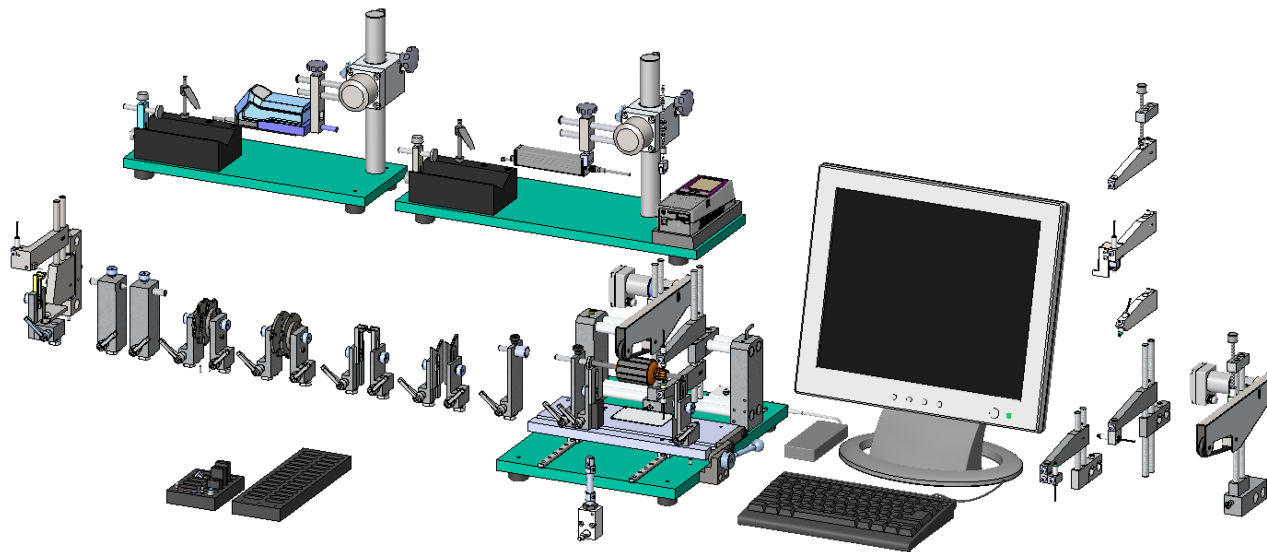

## Commutator Measurement Device BK730

---

## Table of contents

<b>1</b>	<b>Example commutators.....</b>	<b>1</b>	<b>13</b>	<b>Training.....</b>	<b>32</b>
<b>2</b>	<b>Example equipment .....</b>	<b>2</b>	13.1	Training Level 1.....	32
<b>3</b>	<b>Basic module .....</b>	<b>3</b>	13.2	Training Level 2.....	33
<b>4</b>	<b>Test piece adapters .....</b>	<b>4</b>	13.3	Service.....	34
4.1	Prisms 4.....		<b>14</b>	<b>Setup master with accessories .....</b>	<b>35</b>
4.2	Setting pieces for prisms.....	7	14.1	Setup master with measurement report.....	35
4.3	Axial stops.....	8	14.2	Setup master with DAkkS test report.....	37
4.4	Blocks with tip .....	9	14.3	Storage compartment for setup masters.....	39
4.5	Star prisms .....	10	<b>15</b>	<b>Measuring equipment capacity .....</b>	<b>40</b>
<b>5</b>	<b>Measuring sensor .....</b>	<b>11</b>	<b>16</b>	<b>Workplace versions .....</b>	<b>41</b>
5.1	Measuring sensor with electronic accessories .....	11	<b>17</b>	<b>Transport, dimensions, weights .....</b>	<b>42</b>
5.2	Measuring sensor holder.....	12	<b>18</b>	<b>Contact information .....</b>	<b>44</b>
<b>6</b>	<b>Measuring inserts .....</b>	<b>17</b>	<b>19</b>	<b>Document history.....</b>	<b>45</b>
6.1	Standard parts.....	17			
6.2	Special productions.....	18			
<b>7</b>	<b>Drives</b>	<b>19</b>			
7.1	Pressing on the pack.....	19			
7.2	Pressing on the shaft/worm .....	20			
7.3	Wear parts.....	21			
<b>8</b>	<b>NOK lock.....</b>	<b>22</b>			
<b>9</b>	<b>Hand-held scanner.....</b>	<b>23</b>			
<b>10</b>	<b>Roughness measurement .....</b>	<b>24</b>			
10.1	Roughness measuring device system Mitutoyo.....	24			
10.2	Roughness measuring device system Hommel.....	26			
<b>11</b>	<b>Software.....</b>	<b>28</b>			
11.1	Program versions.....	28			
11.2	Additional options .....	29			
<b>12</b>	<b>IT and hardware .....</b>	<b>30</b>			

# 1 Example commutators

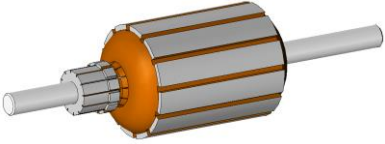
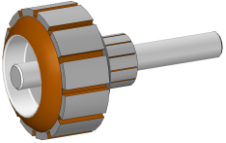
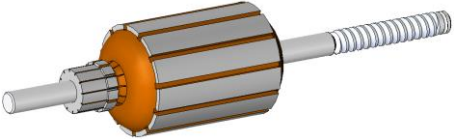
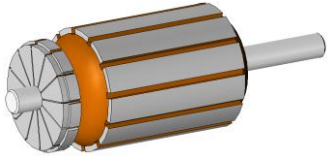
Representation	Explanation
	Examples of commutators and armatures of different builds
	
	
	

## 2 Example equipment

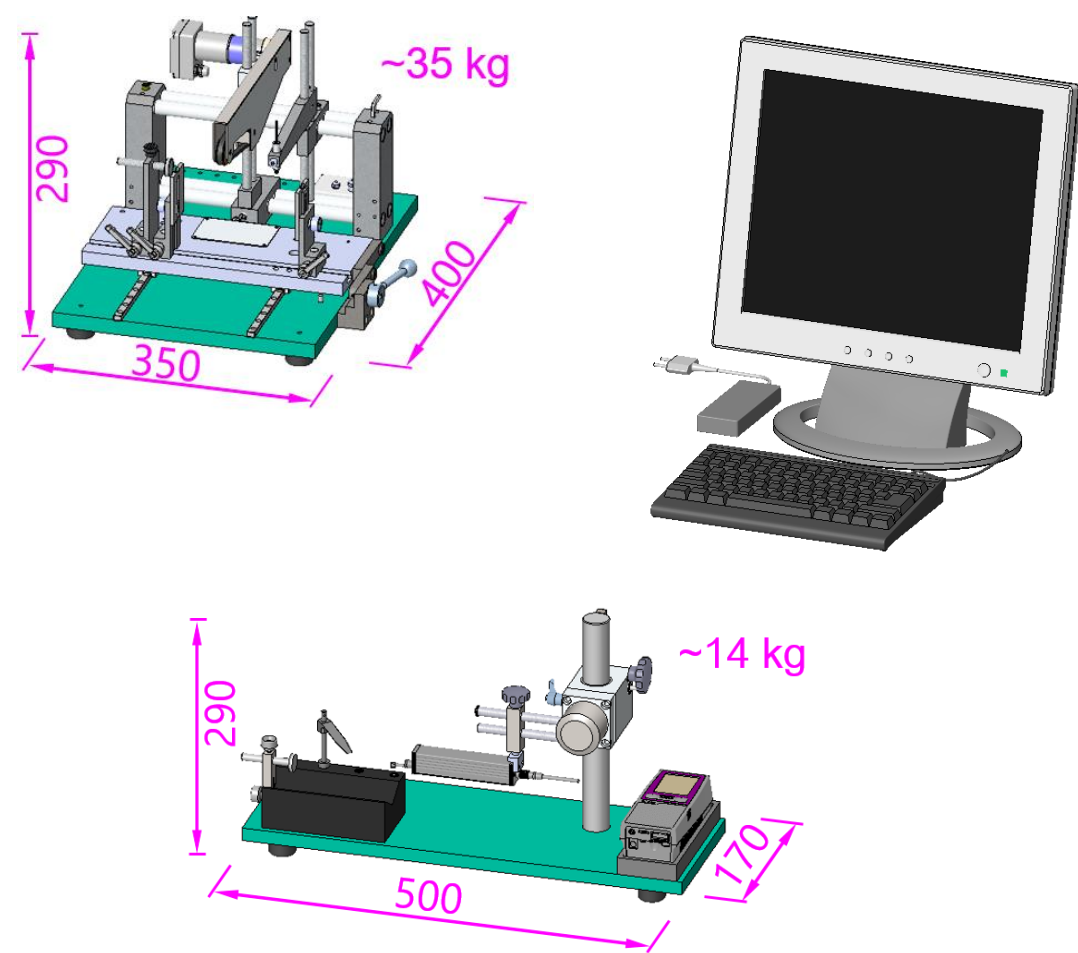
Representation	Explanation
 <p>~35 kg</p> <p>~14 kg</p>	<p>Equipment may comprise:</p> <ul style="list-style-type: none"> <li>• BK730-001-000 Basic module</li> <li>• BK730-101-000 Prism pair <math>\varnothing 3...12</math></li> <li>• BK730-105-000 Stop with disc</li> <li>• BK730-201-000 Holder adapter</li> <li>• BK730-202-000 Vertical sensor holder</li> <li>• BK730-401-000 Flat belt drive</li> <li>• BK740-000-000 Roughness Mitutoyo</li> <li>• Screen 19" TFT, default resolution 1024*768 pixels</li> <li>• Keyboard with trackball</li> <li>• BK730-910-001 Software Basic Version</li> <li>• BK730-910-001 MSA 1</li> </ul> <p>Technical documentation (digitally on CD):</p> <p>Operating manual "Commutator test device BK730"</p> <p>Documentation of the software "kommutator.info®"</p> <p>EC declaration of conformity</p> <p>Calibration certificate of measuring sensor</p> <p>Measurement protocol limits for setup master</p> <p>Accessories list with order numbers of the wear parts</p> <p>Circuit diagram</p> <p>Assembly drawing</p> <p>Video with short instructions</p>

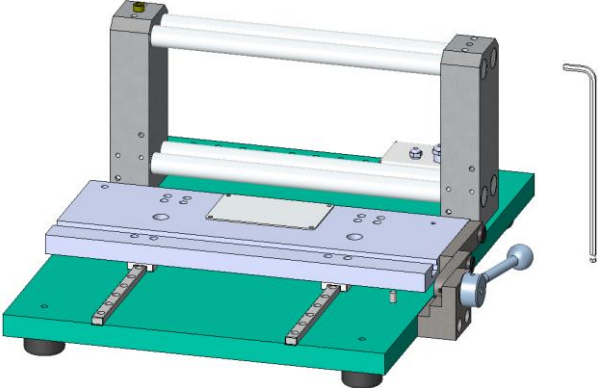
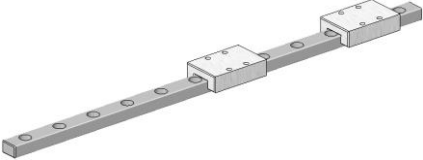

### 3 Basic module

Piece	Order no.	Representation	Explanation
	BK730-001-000 Basic module		<p>Basic module with:</p> <ul style="list-style-type: none"> <li>Movable carriage for test piece adapter (insertion and measurement positions)</li> <li>Frame for measuring sensor adapters and drive</li> <li>Socket wrench as universal tool</li> <li>Plug housing for connection to IT and hardware</li> </ul> <p>The basic module can be customised with accessories.</p>
	KT001493 KT001494 Linear rail guide		<p>Wear part</p> <p>Linear rail guide with 2 guide carriages</p>

## 4 Test piece adapters

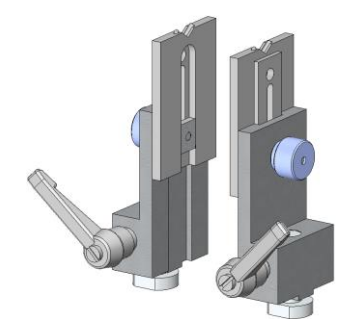
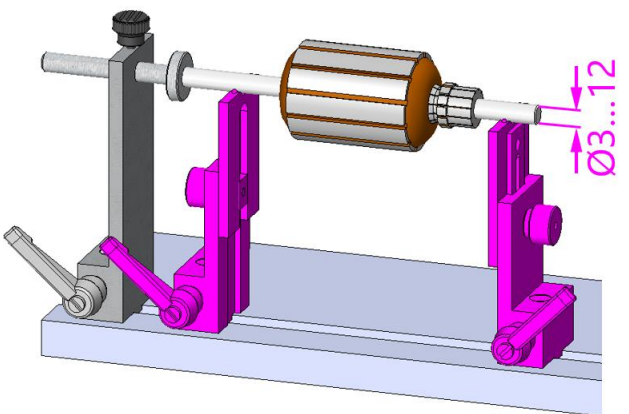
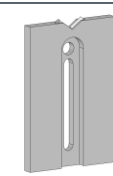
### 4.1 Prisms

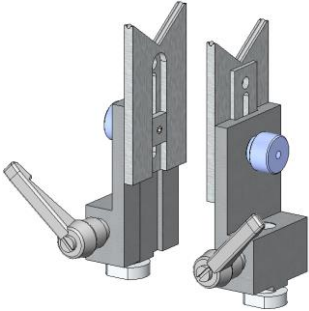
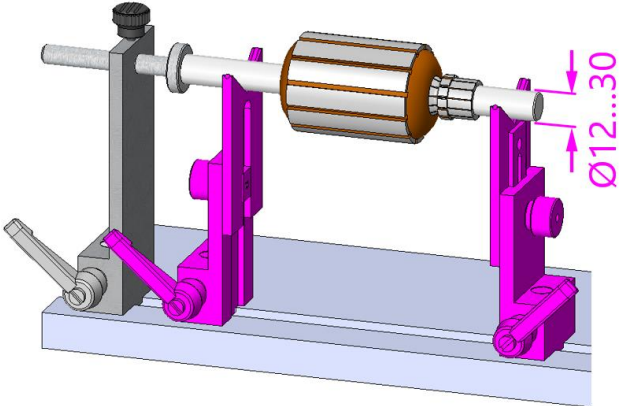
Piece	Order no.	Representation	Application	Explanation
	BK730-101-000 Prism $\varnothing 3...12$			<p>Prism pair 1x left-hand version 1x right-hand version</p> <p>Height-adjustable</p> <p>Adapter for test pieces with bearing journals <math>\varnothing 3...12</math> mm</p>
	BK730-101-001 Prism $\varnothing 3...12$ head			Wear part

Piece	Order no.	Representation	Application	Explanation
	BK730-103-000 Prism $\varnothing 12...30$			Prism pair <ul style="list-style-type: none"> <li>• 1x left-hand version</li> <li>• 1x right-hand version</li> </ul> Height-adjustable  Adapter for test pieces with bearing journals $\varnothing 12...30$ mm
	BK730-103-001 Prism $\varnothing 12...30$ head			Wear part

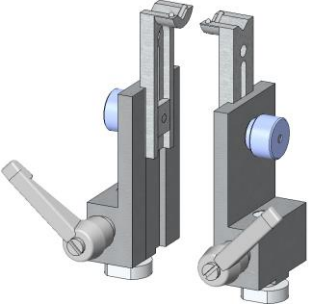
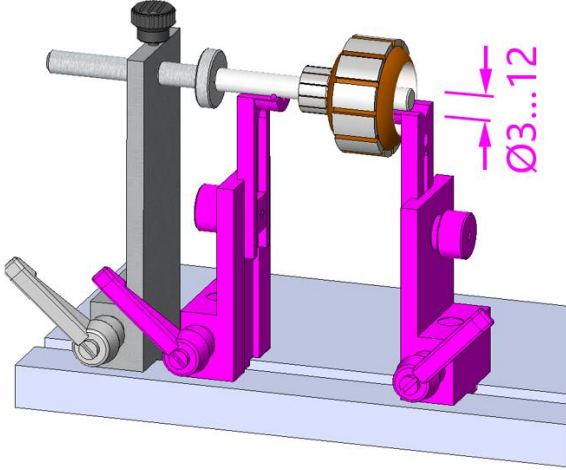
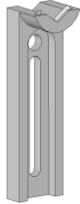

Piece	Order no.	Representation	Application	Explanation
	BK730-107-000 Prism cranked $\varnothing 3...12$			Prism pair <ul style="list-style-type: none"> <li>• 1x left-hand version</li> <li>• 1x right-hand version</li> </ul> Height-adjustable  Adapter for test pieces with inner shaft and bearing journals $\varnothing 3...12$ mm
	BK730-107-001 Prism cranked $\varnothing 3...12$ head			Wear part

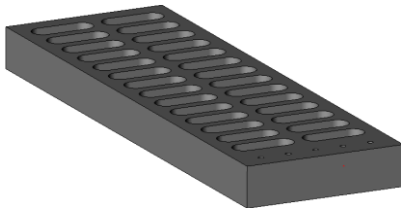
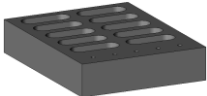
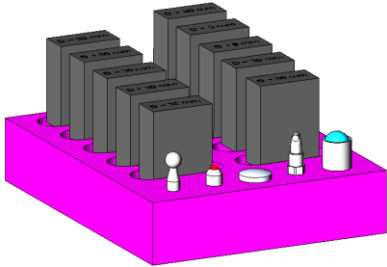
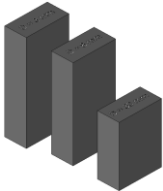
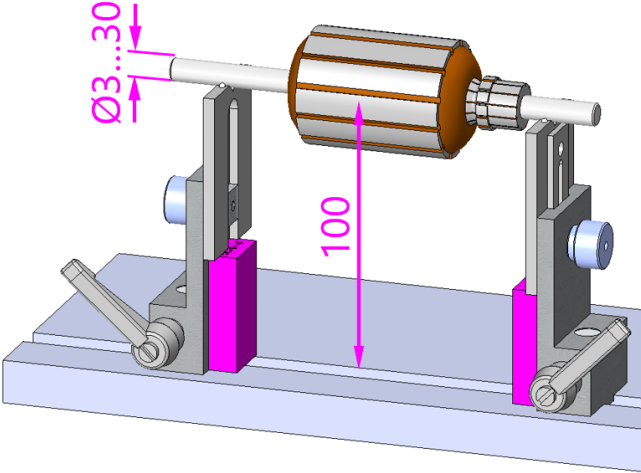

## 4.2 Setting pieces for prisms

Piece	Order no.	Representation	Application	Explanation
	BK730-116-001 Tray set of 28			Tray of hard PVC for 28 setting pieces and 5 measuring sensors
	BK730-116-002 Tray set of 10			Tray of hard PVC for 10 setting pieces and 5 measuring sensors
	BK730-116-003 Setting piece for $\varnothing 3$  BK730-116-004 Setting piece for $\varnothing 4$  BK730-116-005 Setting piece for $\varnothing 5$ . . . BK730-116-030 Setting piece for $\varnothing 30$			Setting pieces serve to easily set the height-adjustable prisms to a consistent test height of 100 mm.  e.g. for test piece bearing journals $\varnothing 8$ : BK730-116-008 setting piece for $\varnothing 8$

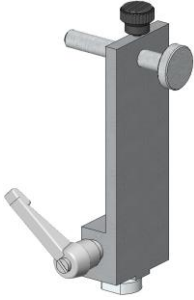
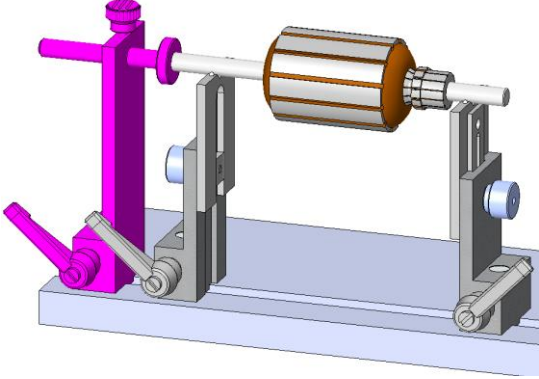

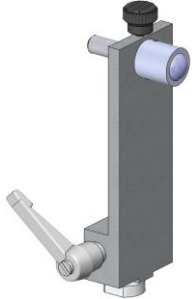
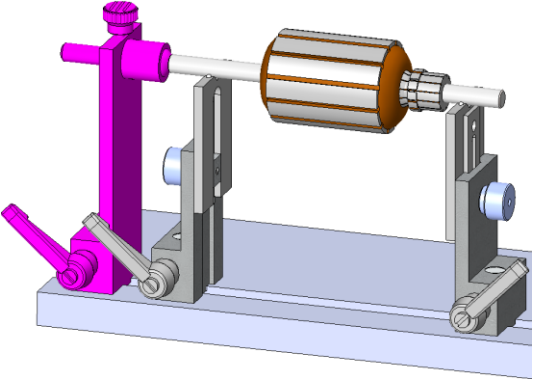
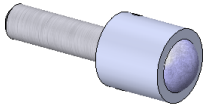
## 4.3 Axial stops

Piece	Order no.	Representation	Application	Explanation
	BK730-105-000 Stop with disc			Unilateral stop with disc for positioning of the test piece
	BK730-105-002 Stop disc			Wear part
	BK730-114-000 Stop with ball			Unilateral stop with ball for positioning of the test piece
	BK730-115-000 Stop ball			Wear part

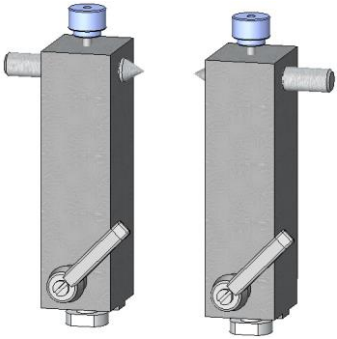
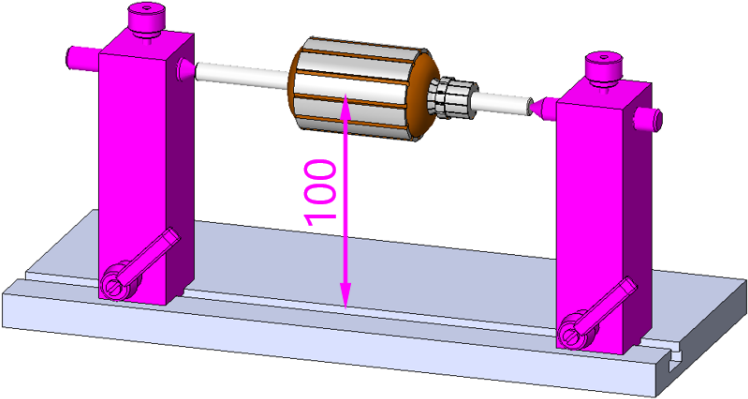
## 4.4 Blocks with tip



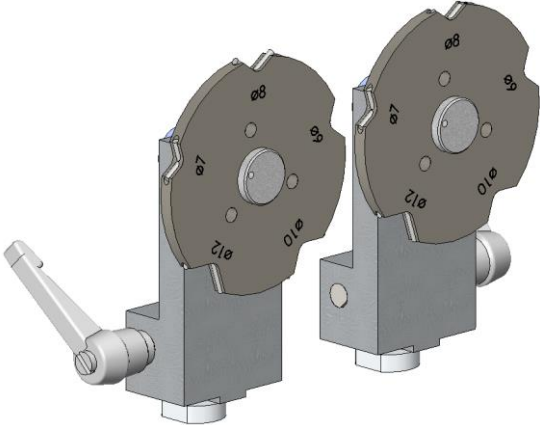
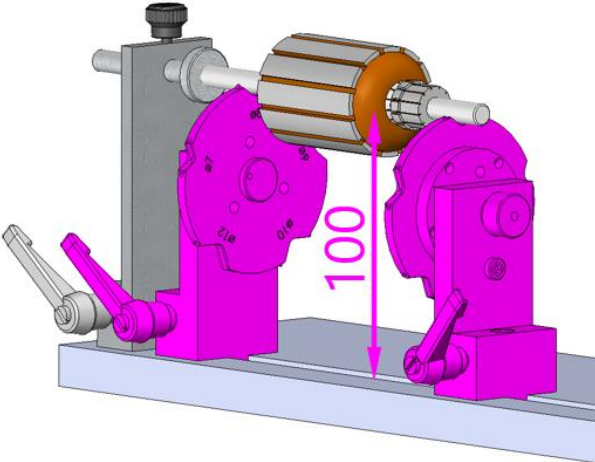

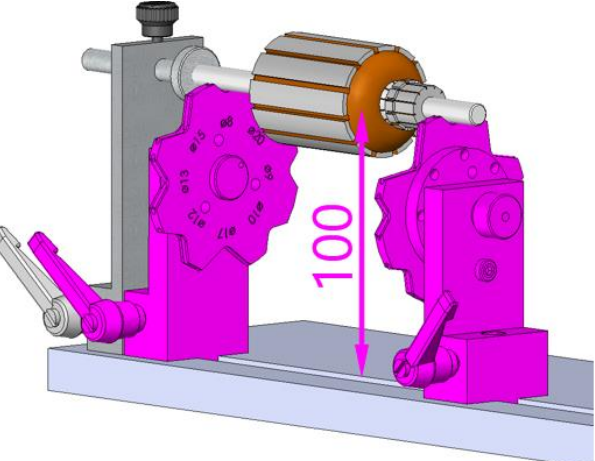
Piece	Order no.	Representation	Application	Explanation
	<p>BK730-109-000 Block with tip</p>			<p>Pair of blocks with tip 1x left-hand version 1x right-hand version</p> <p>Test height 100 mm</p> <p>Adapter for test pieces with centring hole</p>

## 4.5 Star prisms

Piece	Order no.	Representation	Application	Explanation
	<p>BK730-112-000 Star prism 5-fold</p>			<p>Star prism pair 1x left-hand version 1x right-hand version</p> <p>Turnable star disc for quick changing between 5 different diameters</p> <p>Latches in every position Consistent test height 100 mm</p> <p>ø7 ø8 ø9 ø10 ø12</p>
	<p>BK730-111-000 Star prism 8-fold</p>			<p>Star prism pair 1x left-hand version 1x right-hand version</p> <p>Turnable star disc for quick changing between 8 different diameters</p> <p>Latches in every position Consistent test height 100 mm</p> <p>ø8                    ø13 ø9                    ø15 ø10                  ø17 ø12                  ø20</p>

## 5 Measuring sensor

### 5.1 Measuring sensor with electronic accessories

Piece	Order no.	Representation	Explanation
	KT001514		Digital measuring sensor DP1-S (Solartronmetrology) Measuring range 1 mm
	KT018360		Digital measuring sensor DP2-S (Solartronmetrology) Measuring range 2 mm
	KT001868		Digital measuring sensor DP5-S (Solartronmetrology) Measuring range 5 mm
	KT001408		T-Con connector (Solartronmetrology)
	KT001746		USB interface module (Solartronmetrology)
	KT001407		Digital input-output module (Solartronmetrology)
	KT013217		Switching mains unit for Orbit modules (Solartronmetrology) AC Power In, 5 VDC Out

## 5.2 Measuring sensor holder

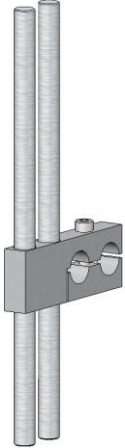
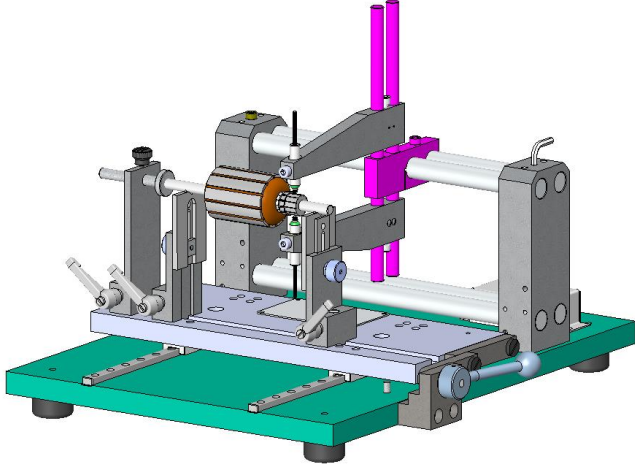
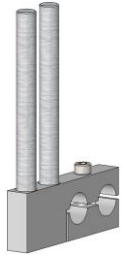
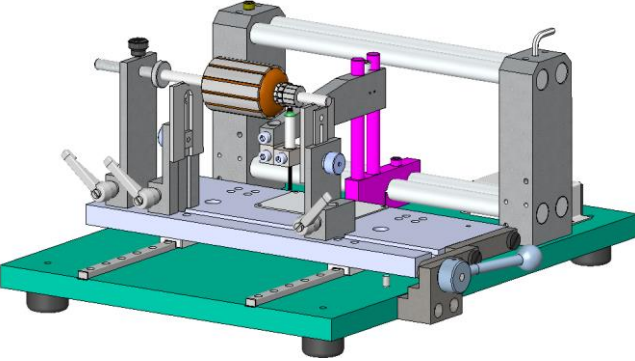
Piece	Order no.	Representation	Application	Explanation
	BK730-201-000 Holder adapter			Holder adapter, universal, for equipment with various sensor holders
	BK730-209-000 Holder adapter			Holder adapter, short version for narrow space

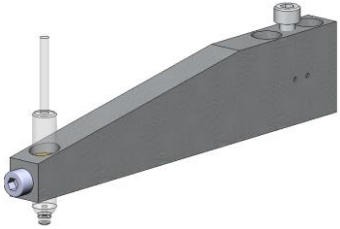
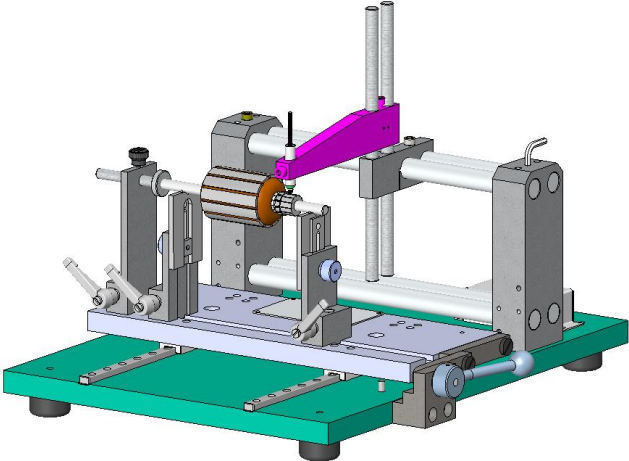
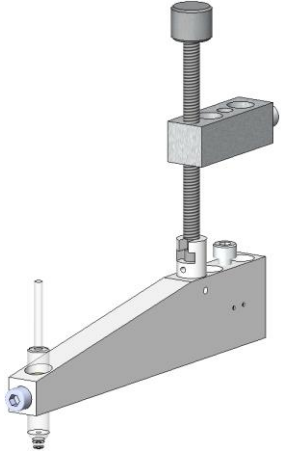
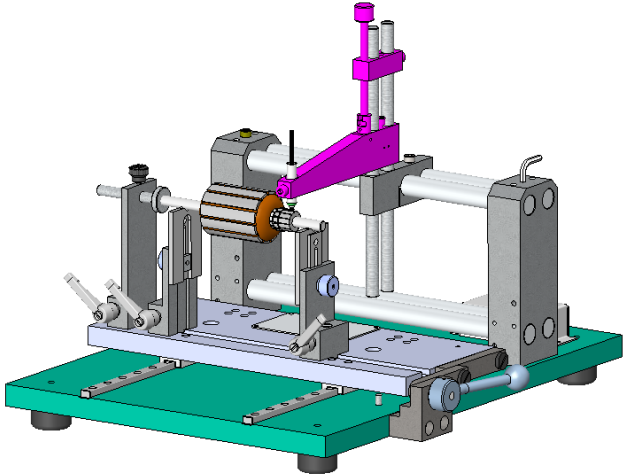
Piece	Order no.	Representation	Application	Explanation
	BK730-202-000 Vertical sensor holder			Sensor holder as a vertical adapter for measuring sensors
	BK730-205-000 Vertical sensor holder Fine adjustment			Sensor holder with adjustment screw for fine adjustment of the scanning position

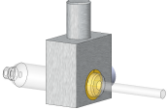
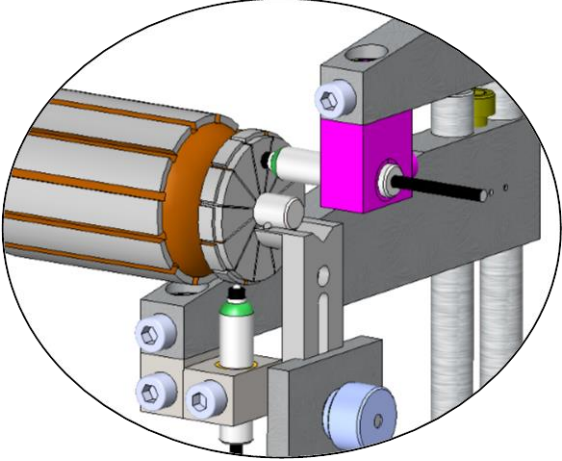
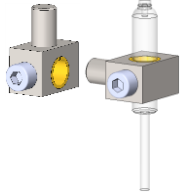
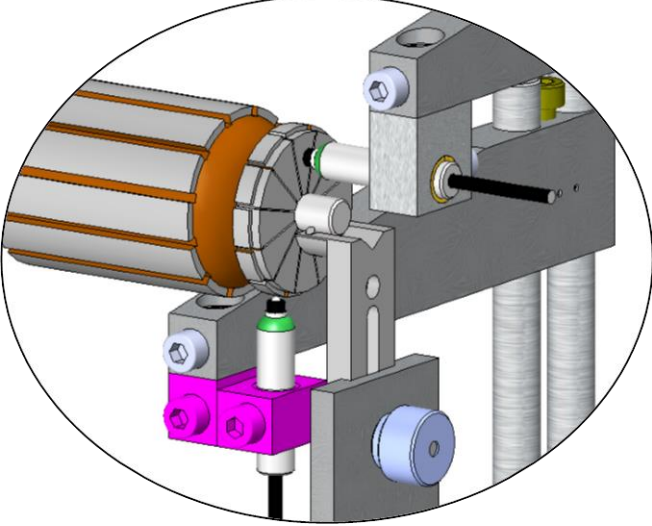

Piece	Order no.	Representation	Application	Explanation
	BK730-203-000 Adapter for horizontal sensor accommodation			Adapter for holding a horizontally arranged measuring sensor
	BK730-204-000 Adapter for sensor offset			Adapter pair  For varying the measuring sensor position in narrow space



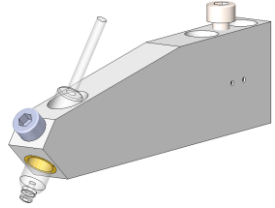
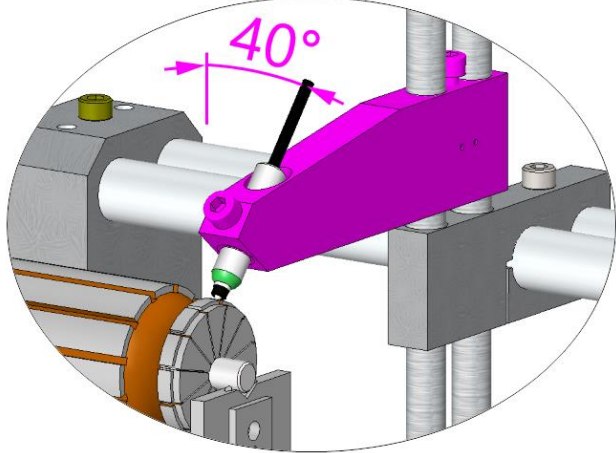
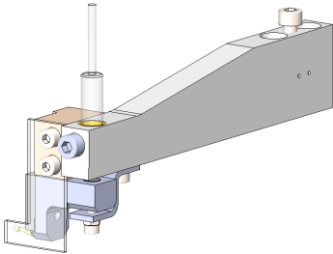
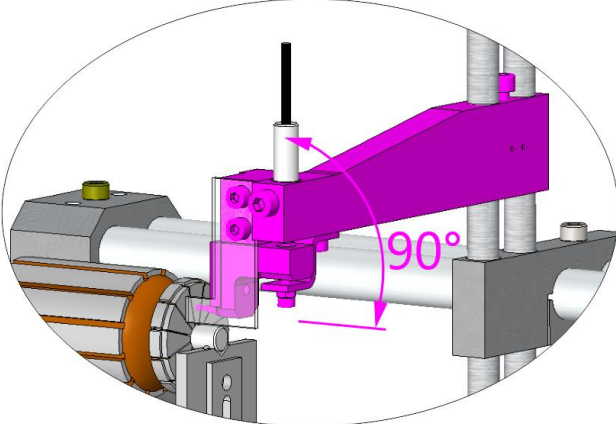

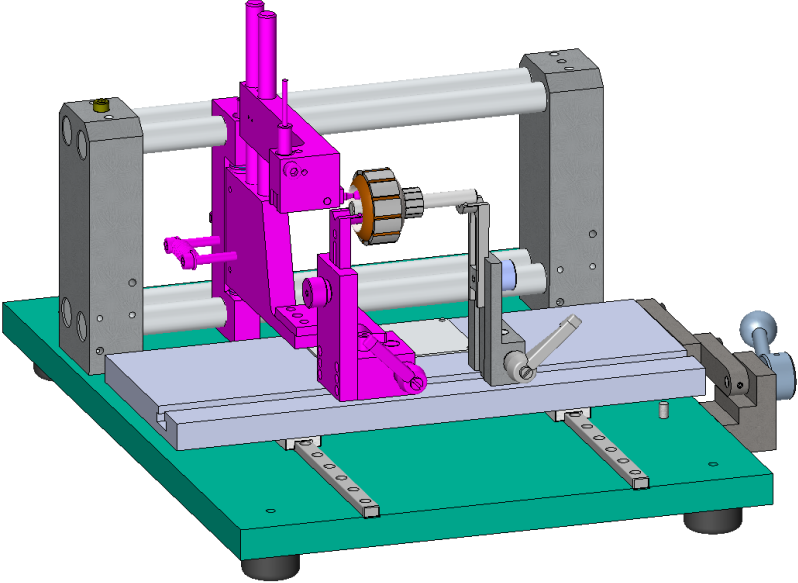
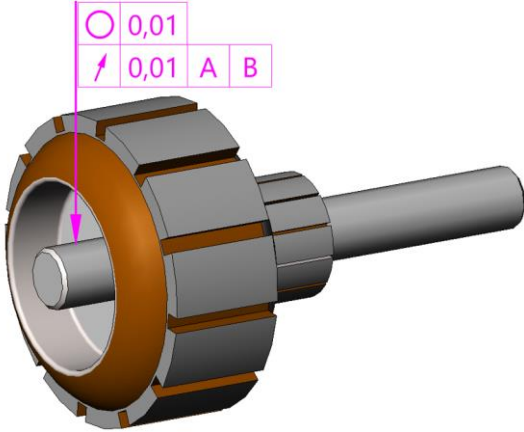
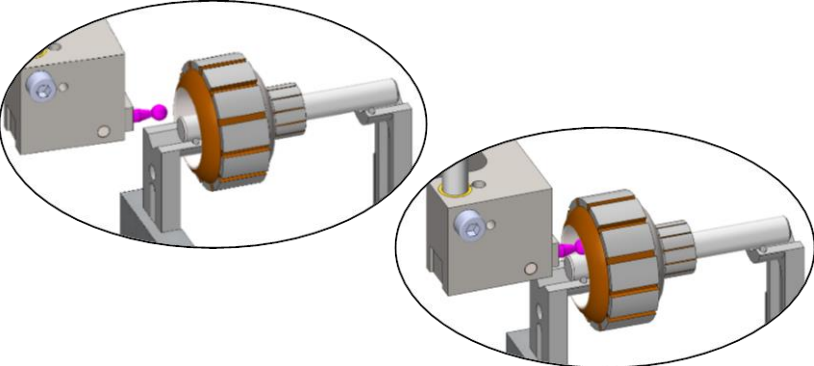



Piece	Order no.	Representation	Application	Explanation
	BK730-206-000 Angled sensor holder			Sensor holder as adapter for a measuring sensor for scanning with an angle of 40° (suitable for all commutator types)
	BK730-207-000 Sensor holder with angle lever			Sensor holder with 90°-deflection as adapter for a measuring sensor for scanning a front face  Measuring sensor presses on the front face with spring force

Piece	Order no.	Application	Explanation
	<p>BK730-506-000 Swivelling sensor holder</p>		<p>Sensor holder with cranked prism for the concentricity check of test pieces with inner shaft</p>  <p>Automatic swivel mechanism permits collision-free insertion of the test piece</p> 

## 6 Measuring inserts

### 6.1 Standard parts

Piece	Order no.	Representation
	KT012228 Measuring insert Disc ø10	
	KT005622 Measuring insert Crowned ø10	
	KT0018684 Measuring insert Ball ø2	
	KT010587 Measuring insert Ball ø5 Carbide	
	KT005176 Measuring insert Transverse cylinder ø2 Carbide	

Piece	Order no.	Representation
	KT018693 Measuring insert Ruby ball ø3	
	Others upon request	

## 6.2 Special productions

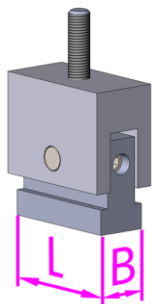
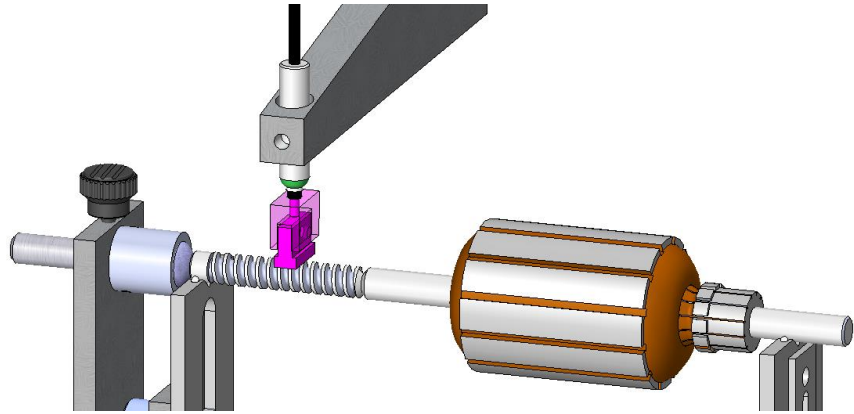
Piece	Order no.	Representation	Application	Explanation
	<p>BK730-302-000 Moulded element, oscillating, straight</p>			<p>Moulded element Custom production in sizes "L" and "B"</p> <p>Can be screwed into measuring sensor (thread M2.5) Adjusts to the surface to be scanned by oscillating E.g., for measuring concentricity deviations on thread surfaces</p>

## 7 Drives

### 7.1 Pressing on the pack

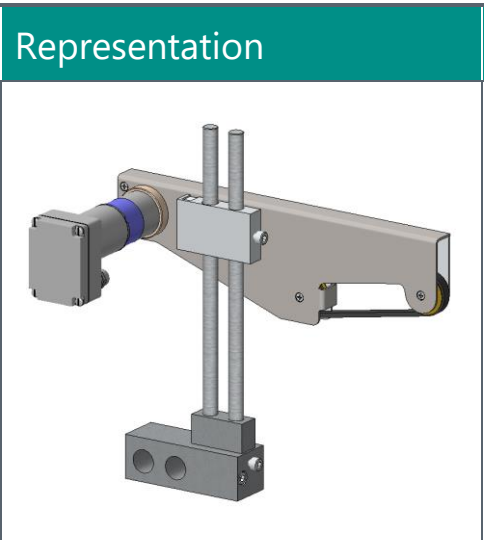
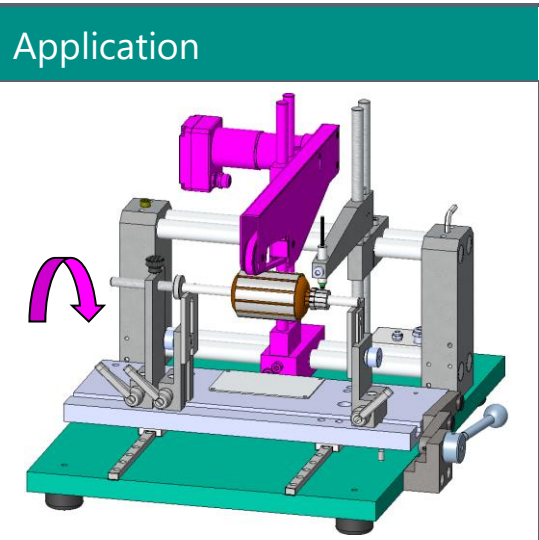
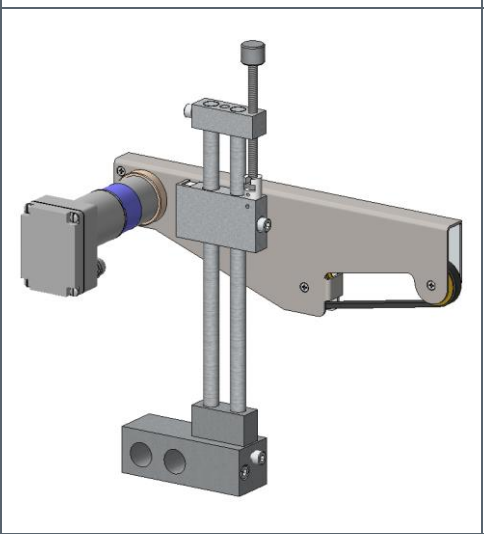
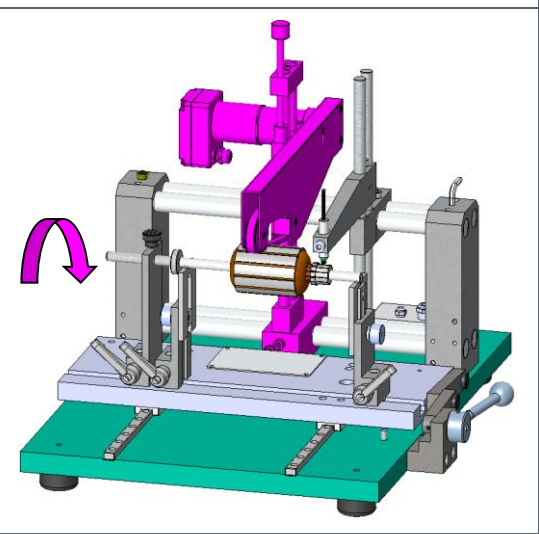
Piece	Order no.	Representation	Application	Explanation
	BK730-401-000 Flat belt drive W6, L500			Drive with 6 mm wide belt  Turns the commutator while measuring by pressing on the pack
	BK730-402-000 Flat belt drive fine adjustment W6, L500			Drive with 6-mm-wide belt with adjustment screw for fine setting of the height  Turns the commutator while measuring by pressing on the pack

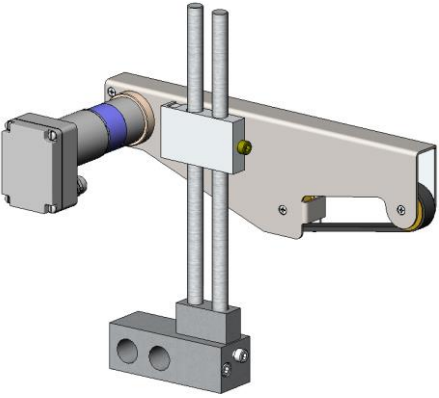
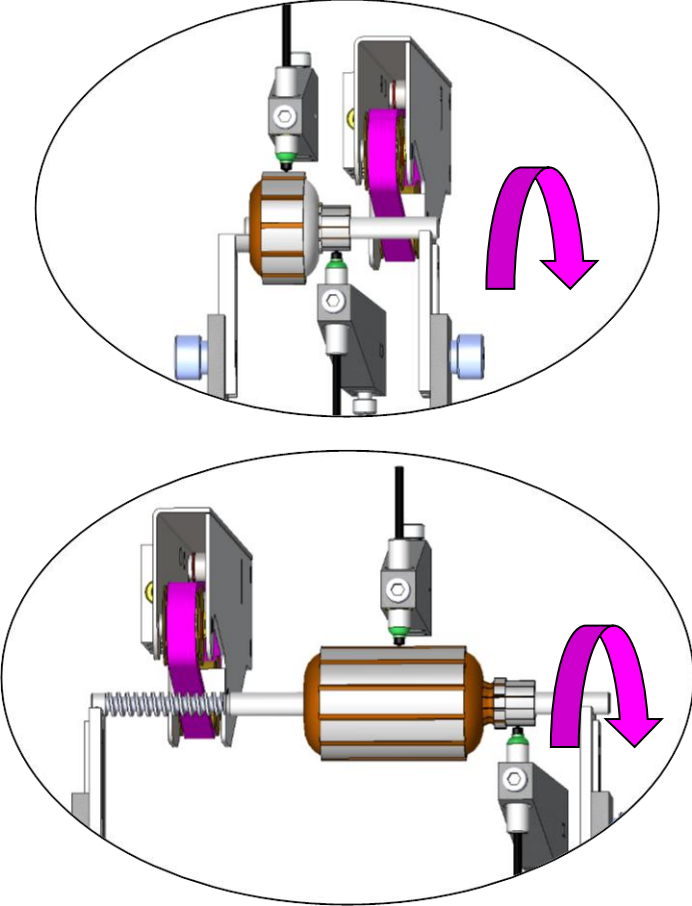

## 7.2 Pressing on the shaft/worm

Piece	Order no.	Representation	Application	Explanation
	<p>BK730-403-000 Flat belt drive W10, L500</p>			<p>Drive with 10 mm wide belt</p> <p>Turns the commutator while measuring by pressing on the shaft or worm</p>

## 7.3 Wear parts

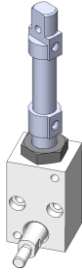
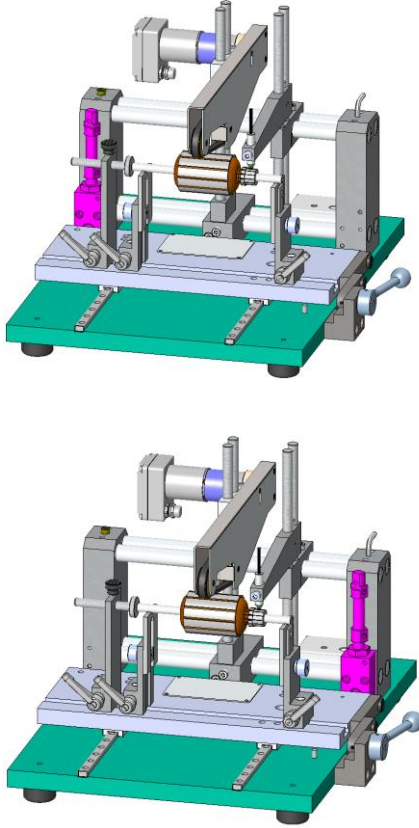

Piece	Order no.	Representation	Explanation
	KT001415 Toothed belt Width 6mm Length 500 mm		Wear part
	KT005221 Toothed belt Width 10mm Length 500 mm		Wear part
	KT001409 Servo motor with gear		Wear part
	KT003631 Plain bearing		Wear part

## 8 NOK lock

Piece	Order no.	Representation	Application	Explanation
	<p>BK730-505-000 NOK lock</p>			<p>Lock at NOK The test piece can only be removed by acknowledging in the software if NOK. The carriage is pneumatically locked with the test piece adapter for this.</p>  <p>Accessories: Locking cylinder installed on the right or left depending on space</p> <ul style="list-style-type: none"> <li>• Digital input-output module (Solartronmetrology)</li> <li>• Power supply 24 V</li> <li>• Maintenance unit combination</li> <li>• Pneumatic switching valves</li> <li>• Siemens LOGO!® control</li> </ul> <p>Prerequisite: Pneumatic connection 6 bar</p>



## 9 Hand-held scanner

Piece	Order no.	Representation	Explanation
	KT019950 PSC QS-1000 Quick Scan		Barcode scanner <ul style="list-style-type: none"> <li>• with cable</li> <li>• with stand</li> <li>• Handheld device</li> <li>• USB port</li> </ul>
	KT019951 Cino FuzzyScan F560		Barcode scanner <ul style="list-style-type: none"> <li>• Wireless</li> <li>• Handheld device</li> <li>• USB port</li> </ul>
	Another Types "FuzzyScan"  on request		





For reading order and/or part numbers that are printed on the accompanying documents as barcodes

# 10 Roughness measurement

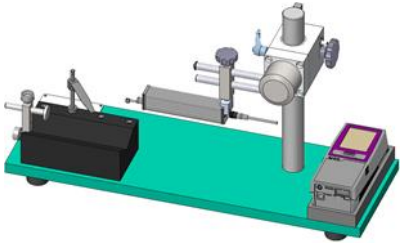
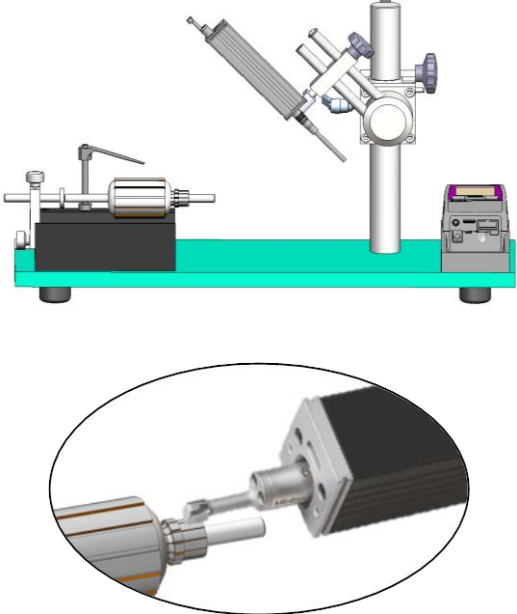



## 10.1 Roughness measuring device system Mitutoyo

Piece	Order no.	Representation	Application	Explanation
	<p>BK740-000-000 Mitutoyo roughness measuring device</p>			<p>Device for measuring surface roughness with roughness measuring device Mitutoyo SJ-210</p> <p>The roughness measurement device can be turned out upwards for test piece change; application to the surface takes place with a gentle dampening</p> <p>Strictly for information: Connection to an old SJ-201P device still available at the customer's site is also possible on request</p>

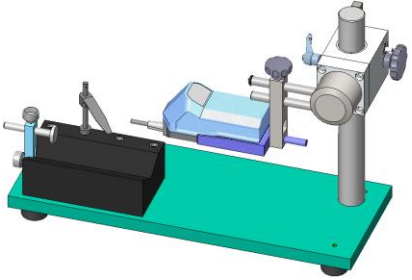
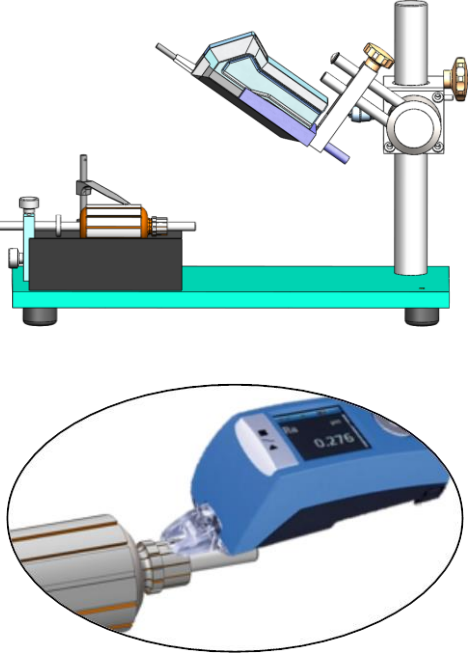
Piece	Order no.	Representation	Explanation	
	KT000905 Blank holder spring		Wear part	
	KT011927 Rotation brake		Wear part	
	KT018313 Roughness measurement device SJ-210 Mitutoyo		Spare part  The roughness t measurement device is not a standard product. It is configured individually, depending on the requirements of the surface quality of the commutator to be measured.  Individual accessories: <ul style="list-style-type: none"> <li>• Precision roughness specimen</li> <li>• Detector</li> </ul>	
	KTxxx Specimen 1,0 Mitutoyo		Precision roughness specimen Ra 1,0 $\mu\text{m}$ / Rmax 3,4 $\mu\text{m}$	Accessories for recalibration  suitable for Roughness measurement device with works calibration certificate Mitutoyo SJ-210 size of Specimen 32 x 22 mm packed in plastic case
	KTxxx Specimen 3,0 Mitutoyo		Precision roughness specimen Ra 3,0 $\mu\text{m}$ / Rmax 9,5 $\mu\text{m}$	
	KTxxx Detector 2 Mitutoyo		Detector Tip radius 2 $\mu\text{m}$ Measuring force 0,75 mN	Wear part  suitable for Roughness measurement device Mitutoyo SJ-210 Diamond tip
	KTxxx Detector 5 Mitutoyo		Detector Tip radius 5 $\mu\text{m}$ Measuring force 4 mN	

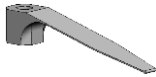
## 10.2 Roughness measuring device system Hommel

Piece	Order no.	Representation	Application	Explanation
	BK741-000-000 Hommel roughness measuring device			<p>Device for measuring surface roughness with roughness measuring device Hommel T1000 with roughness measuring device Hommel-Etamic W5</p> <p>The roughness measurement device can be turned out upwards for test piece change            Application to the surface takes place with a gentle dampening</p> <p>Strictly for information:            Connection to an old T500 device still available at the customer's site is also possible on request</p>

Piece	Order no.	Representation	Explanation	
	KT000905 Blank holder spring		Wear part	
	KT011927 Rotation brake		Wear part	
	KT001676 Roughness measurement device Hommel-Etamic W5		Spare part  The roughness t measurement device is not a standard product. It is configured individually, depending on the requirements of the surface quality of the commutator to be measured. Individual accessories: <ul style="list-style-type: none"> <li>• Precision roughness specimen with works calibration protocol</li> <li>• Precision roughness specimen with DAkkS measurement certificate</li> <li>• Detector</li> </ul>	
	KTxxx Specimen 1,0 Hommel		Precision roughness specimen Ra 1,0 µm / Rmax 3,3 µm	Accessories for recalibration
	KTxxx Specimen 1,0 Homme DAkkS			
	KTxxx Specimen 3,2 Hommel		Precision roughness specimen Ra 3,2 µm / Rmax 10,0 µm	suitable for Hommel-Etamic W5 Material Nickel hard packed in wooden box
	KTxxx Specimen 3,2 Hommel DAkkS			
	KTxxx Detector 2 Hommel		Detector Tip radius 2 µm	Wear part
	KTxxx Detector 5 Hommel		Detector Tip radius 5 µm	suitable for Hommel-Etamic W5 Diamond tip conical 90°

# 11 Software

## 11.1 Program versions



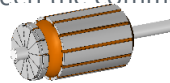

Piece	Order no.	Application	Detailed description in separate document
	BK730-910-001 Basic version	Use in manual workplaces, random sample test	see "kommutator.info documentation" starting on page 8
	BK730-910-002 In-process version	Use in automatic production lines, 100% inspection	see "kommutator.info documentation" starting on page 10
	BK730-910-003 Developer version	Use in the development area, reference measurements after spinning tests, etc.	see "kommutator.info documentation" starting on page 12
	BK730-910-013 Developer version + MD	Second measuring device can be connected for developer version	
	BK730-910-004 Measuring island version	Use with up to 3 measurement devices for different test pieces, random sample testing	see "kommutator.info documentation" starting on page 13

## 11.2 Additional options





Piece	Order no.	Application	Detailed description in separate document
	BK730-910-005 SPC with x-s-control card	SPC evaluation with x-s-control card Including calculation of cp and cpk values (for all program versions)	see "kommutator.info documentation" Page 14
	BK730-910-006 Roughness parameters	Connection of a roughness measurement device (Hommel or Mitutoyo) and application of the results of the roughness test from the commutator test (for all program versions)	see "kommutator.info documentation" Page 15 see "readme_R-profile"
	BK730-910-007 Angle difference	Determination of the angle difference (twist) between grooves of the commutator and pack, according to different calculation methods (for all program versions)	see "kommutator.info documentation" Page 15 see "readme_angle offset"
	BK730-910-008 Concentricity pack with displacement angle	Determining the concentricity at the pack using the instructions on the displacement angle between grooves of commutator and pack (for all program versions)	see "kommutator.info documentation" Page 17
	BK730-910-009 Rectangularity	Determination of rectangularity between the commutator and shaft at front commutators (for all program versions)	see "kommutator.info documentation" Page 15
	BK730-910-010 Barcode reader	Connection of a barcode reader for automatically taking over the part number, customer number, etc. (for all program versions)	see "kommutator.info documentation" Page 14
	BK730-910-011 KI-OPT-PLC	Handover of the measuring details to a PLC via a serial interface (in-process version only)	see "kommutator.info documentation" starting on page 41 see "ki-PLC communication"
	BK730-910-012 CAQ-Export	Manual or automatic generation of customer-specific CAQ output file	see „kommutator.info documentation" Page 86



## 12 IT and hardware



Piece	Order no.	Representation	Explanation
	BK730-920-000 IT and hardware set		Set consisting of: Measuring computer with operating system Windows® Hard disc image for system recovery Screen 19" Switching mains unit RS232 cable <ul style="list-style-type: none"> <li>• Keyboard with trackball (german)</li> </ul>
	BK730-920-001 Measuring computer Mini-PC		Measuring computer Mini-PC, fan-less, current CPU Network connection Interfaces for hardware upgrading Operating system Windows® (current market version)
	BK730-920-002 Backup		Hard disc image for system recovery
	KT001512		Screen 19" default resolution 1024 x 768 pixels

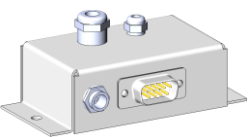

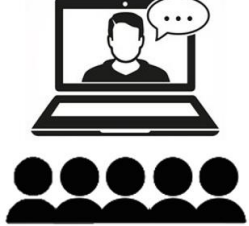

Piece	Order no.	Representation	Explanation
	KT016067		Screen 24" default resolution 1920 x 1080 pixels
	KT005841		Switching mains unit AC 123 V input / 24 V output
	KT015908		RS232 cable
	KT001513		Keyboard with trackball German
	KT001787		Keyboard with trackball English
	BK730-010-000 Plug housing equipped		Spare part

## 13 Training

### 13.1 Training Level 1

Piece	Order no.	Representation	Explanation
	BK730-930-001 Online training Level 1	 <p>Online by video conference with Microsoft- Teams</p>	<p>Training Level 1 Content: teaching basic knowledge For up to 5 persons For servicing personnel, operators, quality assurance representatives German or English 3.5 hours</p>
	BK730-930-002 Inhouse training Level 1	 <p>inhouse only within Germany</p>	<p>Example of training procedure: 10:30 – 11:15 documentation &amp; structure of the measuring device 11:30 – 12:15 commissioning and initialisation of the measuring device 12:45 – 13:15 using an example to create &amp; implement a test plan 13:30 – 14:00 FAQ, troubleshooting</p>

## 13.2 Training Level 2

Piece	Order no.	Representation	Explanation
	BK730-930-003 Online training Level 2	 <p>Online by video conference with Microsoft- Teams</p>	<p>Training Level 2</p> <p>Requirements: Level 1 training already completed Commutator measurement device on site</p> <p>Content: Teaching in-depth knowledge Practical exercises For up to 3 persons For maintenance personnel, operators, quality managers German or English</p> <p>Examination to obtain the certificate: "Ability to operate and maintain the commutator testing device BK730" 5.5 hours</p>
	BK730-930-004 Inhouse training Level 2	 <p>Inhouse only within Germany</p>	<p>Example of training procedure:</p> <p>10:30 – 11:00 explanation of special accessories/roughness measuring device 11:15 – 12:00 independent creation of a test plan I 12:30 – 13:15 independent creation of a test plan II 13:30 – 14:15 troubleshooting 14:30 - 15:00 answering remaining questions 15:00 – 16:00 examination to obtain the certificate</p>

### 13.3 Service

Piece	Order no.	Representation	Explanation
	BK730-930-050 Service	 <p>Online by video conference with Microsoft- Teams</p>	<p>Additional service            Content: assistance according to individual needs            German or English            Appointment by individual arrangement            Contact: <a href="mailto:vertrieb@premetec.de">vertrieb@premetec.de</a>            Entitlement to a total of 6 hours in one year            Billing per half hour or part thereof</p>



# 14 Setup master with accessories

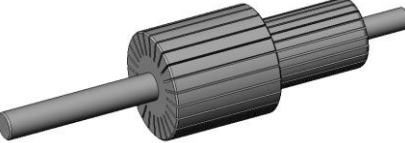
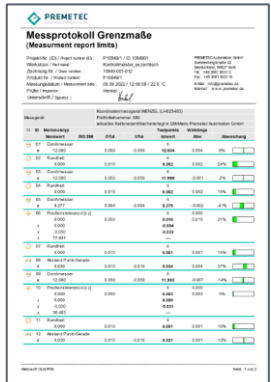
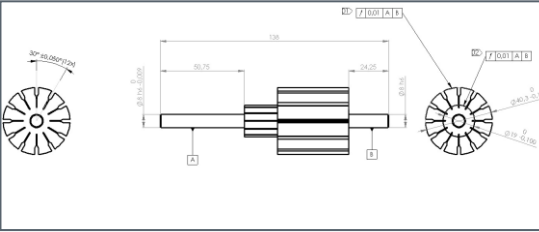
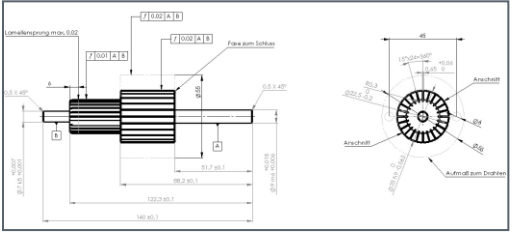

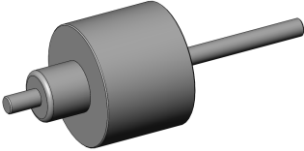
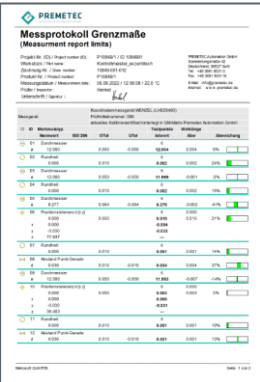
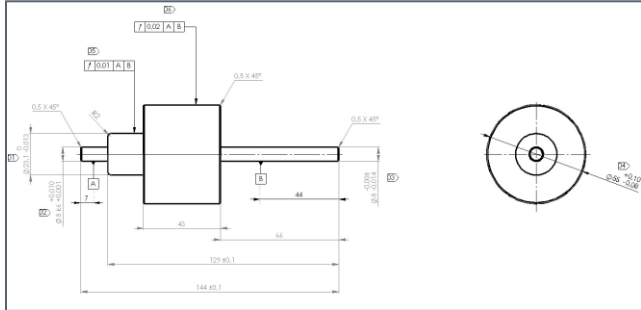
## 14.1 Setup master with measurement report

Piece	Order no.	Representation	Explanation
	BK730-710-001 Setup master 8-fold with measurement report	 <p style="color: magenta; font-weight: bold; font-size: 1.2em;">Example</p>  	Setup master Custom production
	BK730-710-002 Setup master 12-fold with measurement report		Metrics: <ul style="list-style-type: none"> <li>• Diameter</li> <li>• Displacement angle of pitch between commutator and pack</li> <li>• Concentric run</li> <li>• Axial run</li> </ul>
	BK730-710-003 Setup master 16-fold with measurement report		 
	BK730-710-004 Setup master 20-fold with measurement report		
	BK730-710-005 Setup master 24-fold with measurement report		
	BK730-710-006 Setup master 28-fold with measurement report		
	BK730-710-007 Setup master 32-fold with measurement report		

Piece	Order no.	Representation	Explanation
	<p>BK730-710-010 Setup master without pitch with measurement report</p>	 <p style="text-align: center; color: magenta; font-weight: bold; font-size: 1.2em;">Example</p> 	<p>Setup master Custom production</p> <p>Metrics:</p> <ul style="list-style-type: none"> <li>• Diameter</li> <li>• Concentric run</li> <li>• Axial run</li> </ul>  <p>Measurement report with the limit sizes of the setup master</p>

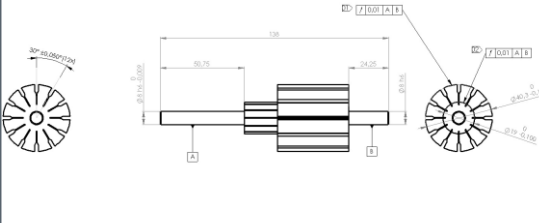
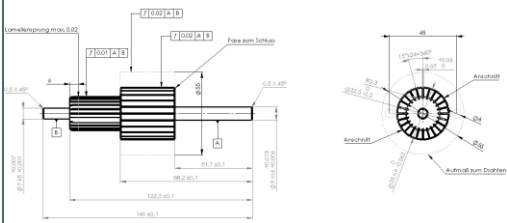
## 14.2 Setup master with DAkkS test report

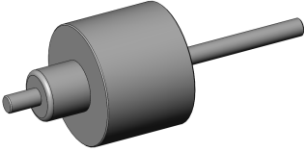
Piece	Order no.	Representation	Explanation
	BK730-710-101 Setup master 8-fold with DAkkS test report	   Prüfbericht Test report	Setup master Custom production
	BK730-710-102 Setup master 12-fold with DAkkS test report		Metrics: <ul style="list-style-type: none"> <li>• Diameter</li> <li>• Displacement angle of pitch between commutator and pack</li> <li>• Concentric run</li> <li>• Axial run</li> </ul>
	BK730-710-103 Setup master 16-fold with DAkkS test report		
	BK730-710-104 Setup master 20-fold with DAkkS test report		
	BK730-710-105 Setup master 24-fold with DAkkS test report		
	BK730-710-106 Setup master 28-fold with DAkkS test report		
	BK730-710-107 Setup master 32-fold with DAkkS test report		

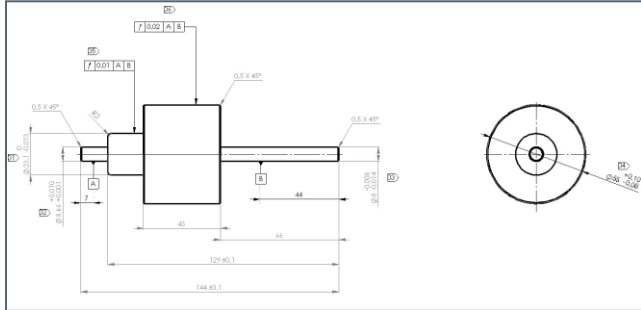
Piece	Order no.	Representation	Explanation
	<p>BK730-710-110 Setup master without pitch with DAkKS test report</p>	 <p style="color: magenta; font-weight: bold; font-size: 1.2em;">Example</p> <div style="border: 1px solid black; padding: 5px; margin-top: 10px;">  <p style="text-align: center;">Prüfbericht Test report</p> </div>	<p>Setup master Custom production</p> <p>Metrics:</p> <ul style="list-style-type: none"> <li>• Diameter</li> <li>• Concentric run</li> <li>• Axial run</li> </ul> <div style="border: 1px solid black; padding: 5px; margin-top: 10px;">  </div> <p>DAkKS test report with the limit sizes of the setup master Measurement in the calibration laboratory with accreditation by the Deutsche Akkreditierungsstelle GmbH</p>

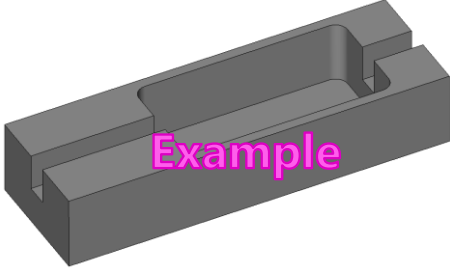
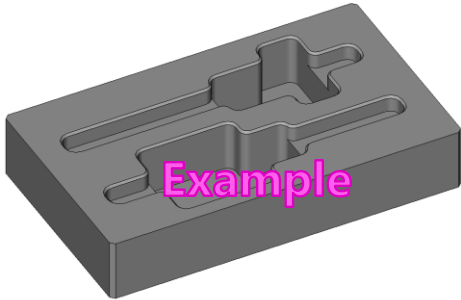
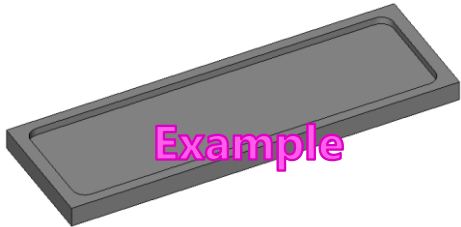

## 14.3 Storage compartment for setup masters

Piece	Order no.	Representation	Explanation
	BK730-720-001 Simple tray		Hard PVC tray adjusted to the shape of the setup master with 1 trough
	BK730-720-002 Multi tray		Hard PVC tray adjusted to the shape of the setup master with 2 or more troughs
	BK730-720-003 Cover		Hard PVC cover matching the tray



# 15 Measuring equipment capacity

Piece	Order no.	Representation	Explanation
	BK730-740-001 MSA 1		Measuring equipment capacity according to MSA procedure 1 for all features
	BK730-740-002 MSA 2		Measuring system capacity according to procedure 2 (Gage R&R) for all features price depending on time expenditure on site

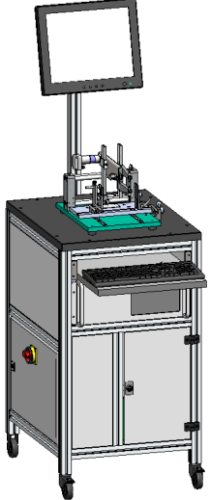
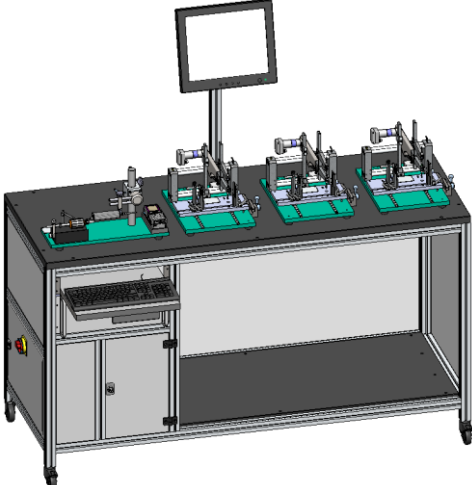
## 16 Workplace versions

Piece	Order no.	Illustration showing exemplary equipment	Explanation
	BK860-100-000 Measuring table trolley narrow	Width x depth x height: 60 x 100 x 180 cm 	Measuring table trolley: Movable by wheels Screen holder Keyboard on fixed tray Lockable compartment Main switch  Example for special equipment: Keyboard in drawer Printer Hand-held scanner NOK lock NOK drawer Air-damped hard stone slab
	BK860-200-000 Measuring table trolley wide	Width x depth x height: 180 x 100 x 180 cm 	

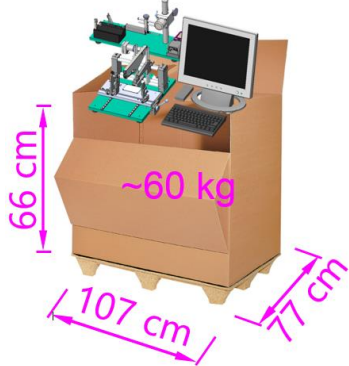
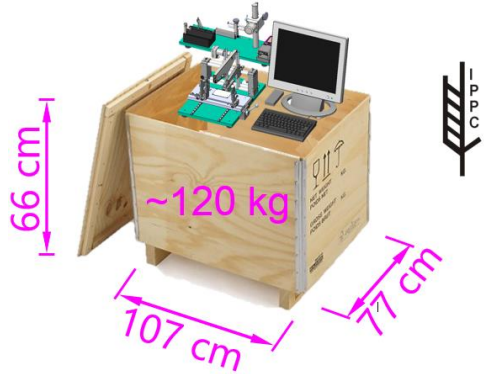
## 17 Transport, dimensions, weights

Piece	Order no.	Representation	Explanation
	BK730-990-001		Transport packaging within EU <ul style="list-style-type: none"> <li>• Card box</li> <li>• Disposable transport pallet</li> <li>• Outer dimensions width x depth x height: 107 x 77 x 66 cm</li> <li>• Gross weight: approx. 60 kg</li> </ul>
	BK730-990-002		Transport packaging international <ul style="list-style-type: none"> <li>• Plywood box</li> <li>• ISPM 15 certified (IPPC)</li> <li>• 2x cross skids for pallet truck</li> <li>• Outer dimensions width x depth x height: 107 x 77 x 66 cm</li> <li>• Gross weight: approx. 120 kg</li> </ul>
	BK730-991-001		Transport <ul style="list-style-type: none"> <li>• Via DAP (2010)</li> <li>• Without customs tariff number</li> <li>• With transport insurance</li> </ul>

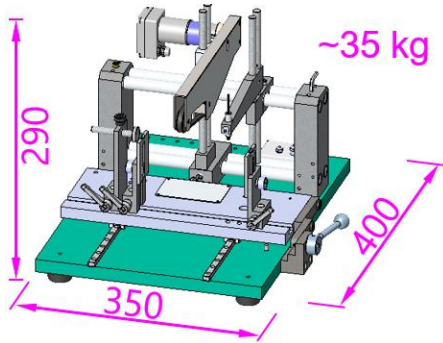
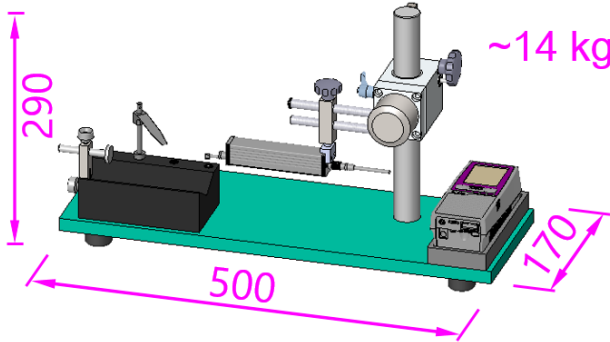
Representation	Explanation
 <p>~35 kg</p> <p>290</p> <p>350</p> <p>400</p>	<p>Commutator test device dimensions (without PC and monitor)</p> <ul style="list-style-type: none"> <li>• Width x depth x height: 350 x 400 x 290 mm</li> <li>• Weight: approx. 35 kg</li> </ul>
 <p>~14 kg</p> <p>290</p> <p>500</p> <p>170</p>	<p>Roughness measurement device dimensions</p> <ul style="list-style-type: none"> <li>• Width x depth x height: 500 x 170 x 290 mm</li> <li>• Weight: approx. 14 kg</li> </ul>

## 18 Contact information

**Address:**

PREMETEC Automation GmbH  
Sommerbergstraße 42  
98527 Suhl

**Contact:**

Phone: +49 (0) 36 81/80 31-0  
Fax: +49 (0) 36 81/80 31-18  
Email: [info@premetec.de](mailto:info@premetec.de)  
Internet: [www.premetec.de](http://www.premetec.de)

**Sales:**

Phone: +49 (0) 36 81/80 31-263  
Email: [vertrieb@premetec.de](mailto:vertrieb@premetec.de)

---

**Copyright**

© 2023 PREMETEC Automation GmbH

The reproduction, storage in electronic form or translation of this catalogue, or any part thereof, is not permitted without written approval from PREMETEC Automation GmbH.

All rights reserved.

## 19 Document history

Issue	Date	Processor	Description of the change / chapter
06/2023	20230613	A. Rode	Creation
07/2023	20230724	A. Rode	Adding: domestic transport Extended: Software versions Updated: hand scanner
08/2023	20230828	A. Rode	Adding: <ul style="list-style-type: none"> <li>• Roughness measurement / Accessories for re-calibration</li> <li>• IT and hardware set</li> </ul> Updated: <ul style="list-style-type: none"> <li>• Basic module</li> <li>• Transport</li> <li>• Measuring inserts / Standard parts</li> </ul>
10/2023	20231011	A. Rode	Updated: <ul style="list-style-type: none"> <li>• Einstellmeister mit Messprotokoll/DAkkS-Prüfbericht</li> </ul> Adding: <ul style="list-style-type: none"> <li>• Hand-held scanner PSC QS-1000 Quick Scan</li> </ul>